

FRONT VIEW  
(DOORS REMOVED)

MOUNTING PAN FOR  
BREAKER, FUSES,  
TERMINAL BLOCKS,  
AND GROUND LUG.

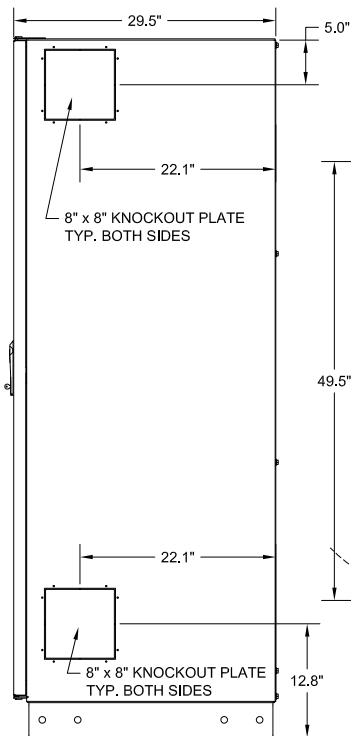

SIDE VIEW

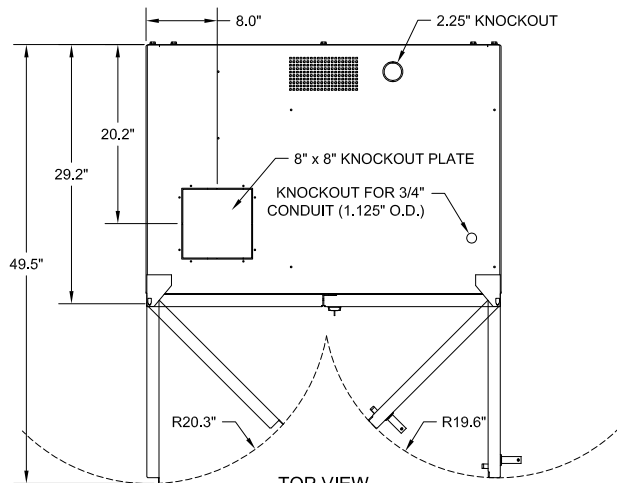

TOP VIEW  
(WITH DOOR SWING)

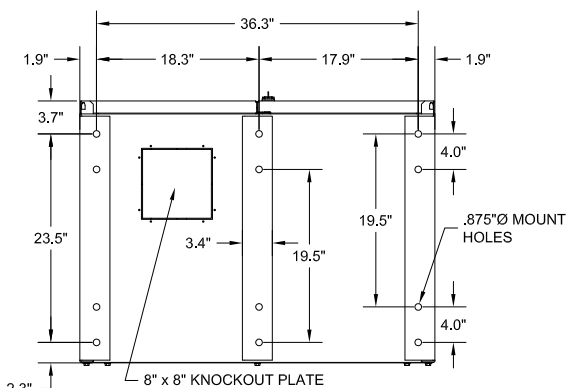
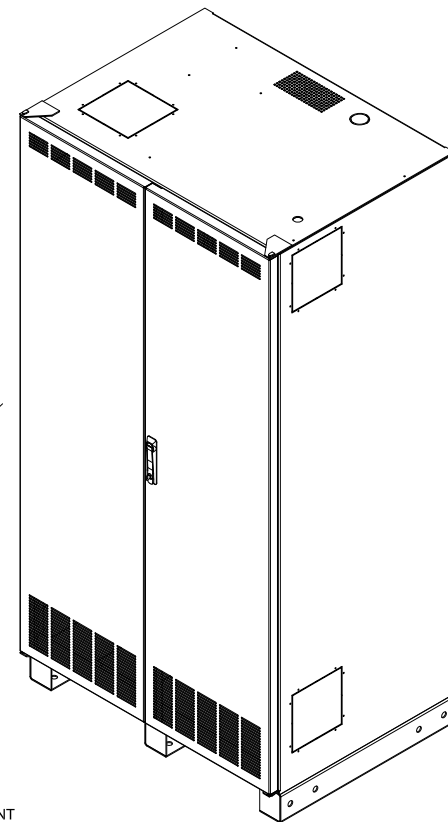

BOTTOM VIEW

**CABINET NOTES:**

EMPTY CABINET WEIGHT: 520

1. NEMA 1 ENCLOSED BATTERY CABINET.
2. FACTORY ASSEMBLED CABINETS ARE LISTED TO UL 1778.
3. HEAVY GAUGE WELDED STEEL CONSTRUCTION.
4. AVAILABLE IN MULTIPLE COLORS OF DURABLE CHIP AND CORROSION RESISTANT POWDER COAT FINISH.
5. FOR EASE OF CONDUIT INSTALLATION, (1) 8" X 8" CONDUIT PLATE IS PROVIDED TO REPLACE A KNOCKOUT IN THE CABINET.
6. BATTERIES CAN BE ACCESSED FROM THE FRONT AND REAR.
7. CABINET CAN BE MOVED WITH PALLET JACK OR FORK LIFT AT PALLET JACK ACCESS POINTS LOCATED AT FRONT OR REAR OF CABINET. FROM THE SIDES, THE CABINET CAN BE MOVED WITH ROL-A-LIFT TYPE EQUIPMENT MOVER. THE CABINET IS ONLY TO BE LIFTED FROM THE BOTTOM.
8. THE BC55S SEISMIC OPTION IS SEISMICALLY QUALIFIED FOR USE WITH THE 2007 & 2010 EDITION OF THE CALIFORNIA BUILDING CODE AND THE 2009 EDITION OF THE INTERNATIONAL BUILDING CODE WHERE CONTINUED OPERATION OF THE SYSTEM IS NECESSARY FOLLOWING A DESIGN LEVEL EARTHQUAKE (SDS=2.0; z/h=1.0).

BC55 BATTERY CABINET			
MECHANICAL DRAWING			
DIMENSIONS ARE IN INCHES		INITIALS	DATE
TOLERANCES:		DRAWN	JRL
DECIMALS: .XX ±.13	ANGLES: ±1°	CHECKED	CH
.XXX ±.062			01/20/11
MATERIAL: SEE NOTES SHEET 1			
FINISH: SEE NOTES SHEET 1			
CAD GENERATED DRAWING DO NOT MANUALLY UPDATE			
SCALE: SEE NTS	SHEET: A	REV: 5	SHEET 1 OF 2
<p>THE INFORMATION CONTAINED IN THIS DRAWING IS THE SOLE PROPERTY OF C&amp;C POWER, INC. ANY REPRODUCTION WITHOUT THE WRITTEN CONSENT OF C&amp;C POWER, INC IS PROHIBITED.</p> <p><b>C&amp;C POWER</b> ENGINEERED POWER PRODUCTS 949 N. Larch Ave. - Elmhurst, IL 60126</p> <p>© 2011 C&amp;C POWER, INC. ALL RIGHTS RESERVED</p>			

TO FUSE OR BREAKER PAN

POS. ↑      ↑ NEG.

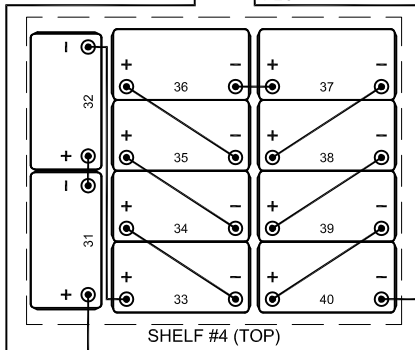

SHELF #4 (TOP)

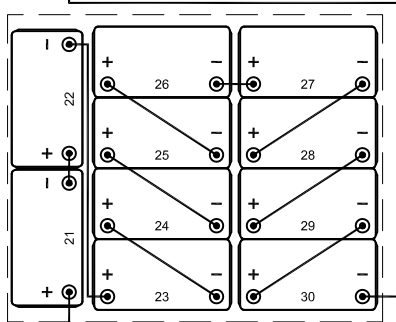

SHELF #3

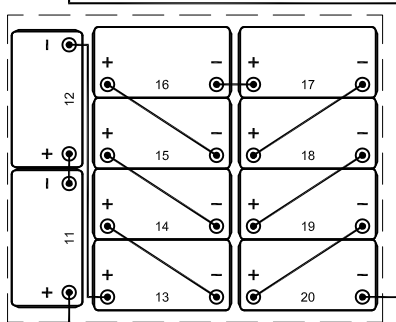

SHELF #2

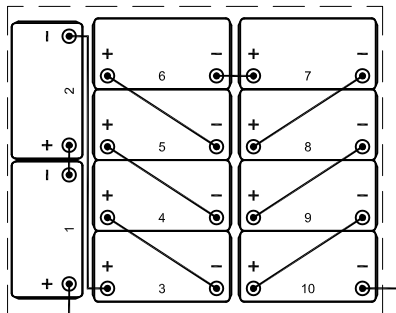

SHELF #1 (BOTTOM)

480 VDC TYPICAL WIRING

**ELECTRICAL NOTES:**

1. ALL INTERNAL WIRING IS UL LISTED, MTW, STYLE, 105C, EXTRA FLEXIBLE CABLE.
2. FUSE IS UL RECOGNIZED, TYPE A50P OR A70P. REPLACE FUSES ONLY WITH SAME TYPE AND RATING AS SUPPLIED WITH SYSTEM!
3. BREAKER IS UL LISTED.
4. CABINETS WITH BREAKERS ARE SHIPPED WITH BREAKER IN THE TRIPPED POSITION.
5. CABINETS ARE SHIPPED WITH BATTERY JUMPER REMOVED TO BREAK STRING VOLTAGE FOR ADDED SAFETY IN SHIPPING.
6. THE TERMINAL BLOCKS ARE UL RECOGNIZED, 600V RATED.
7. CABLES FROM BATTERY CABINET TO UPS SYSTEM ARE OPTIONAL.
8. GROUND CONNECTION IS #6-300MCM MECHANICAL LUG.

BATTERY CONFIGURATIONS	
WPC CAPACITY	MAXIMUM NUMBER OF BATTERIES
200 W	80
300 W	48
350 W	40
400 W	40
500 W	40
540 W	40
620 W	40

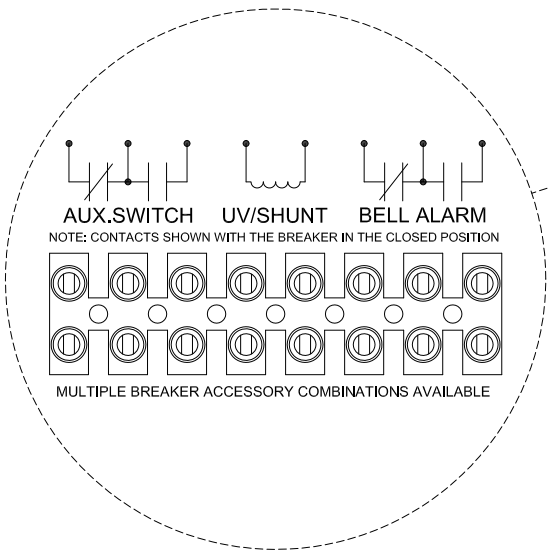

**FUSE PAN**

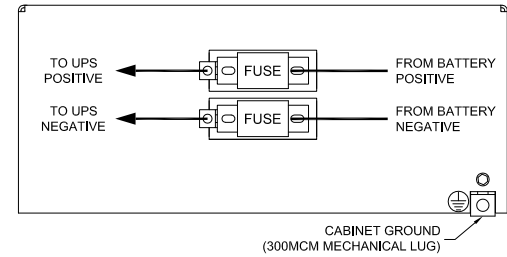

**BREAKER PAN**

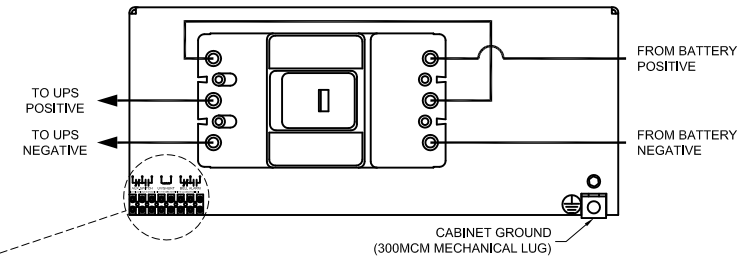

<b>BC55 BATTERY CABINET</b>			
<b>ELECTRICAL DRAWING</b>			
--			
DIMENSIONS ARE IN INCHES	TOLERANCES:	INITIALS	DATE
DECIMALS: .XX ±.13	ANGLES: ±1°	DRAWN JRL	01/20/11
.XXX ±.062		CHECKED CH	01/20/11
MATERIAL: SEE NOTES SHEET 1			
FINISH: SEE NOTES SHEET 1			
CAD GENERATED DRAWING DO NOT MANUALLY UPDATE			
SCALE: SEE NTS	SHEET: A	REV: 5	SHEET 2 OF 2
THE INFORMATION CONTAINED IN THIS DRAWING IS THE SOLE PROPERTY OF C&C POWER, INC. ANY REPRODUCTION WITHOUT THE WRITTEN CONSENT OF C&C POWER, INC IS PROHIBITED.			<b>C&amp;C POWER</b> ENGINEERED POWER PRODUCTS 949 N. Larch Ave. - Elmhurst, IL 60126 © 2011 C&C POWER, INC. ALL RIGHTS RESERVED

DRAWING #: 91455-SDC01-2 REV.5