

**POWERVER – SECURITY PLUS SERIES
DETAILED UPS SPECIFICATION
(12kVA – 15kVA)**



12kVA, 15kVA – POWERVAR Isolated On-Line UPS Specifications

Index

- 1.0 General Description
- 2.0 Models
- 3.0 Mechanical Characteristics
- 4.0 Environmental and Safety Agency
- 5.0 Input
- 6.0 Output - Inverter Operation
- 7.0 Static Bypass Switch (Internal)
- 8.0 Batteries & Charging
- 9.0 Low-Impedance Isolation Transformer
- 10.0 Indicators
- 11.0 User Interfaces
- 12.0 Connections
- 13.0 Additional Options
- 14.0 Computer Platforms Supported
- 15.0 Simplified System Electrical Schematic (200/208/220/230/240 VAC System)
- 16.0 Output Receptacle Panel Connector

12kVA, 15kVA – POWERVAR Isolated On-Line UPS Specifications

1.0 General Description

The following specification describes a UPS with the following characteristics:

- 1.1 Microprocessor controlled
- 1.2 On-line
- 1.3 Output isolation with regulation
- 1.4 Double conversion
- 1.5 Automatic battery charger
- 1.6 Serial and dry-contact user interface
- 1.7 Self-diagnostic capabilities
- 1.8 User selectable options configurable via DIP switches or front panel display
- 1.9 LCD display for system status
- 1.10 Hot swappable user replaceable batteries
- 1.11 Frequency conversion (60Hz in / 50Hz out or 50Hz in / 60Hz out)
- 1.12 Static by-pass

2.0 Models

- 2.1 High voltage models
 - 2.1.1 200/208/220/230/240 VAC, 50/60HZ
 - 2.1.2 VA/Watts Ratings: 12kVA/10.8kW; 15kVA/13.5kW**
- 2.2 The input voltage shall match the output voltage when configured.

3.0 Mechanical Characteristics

- 3.1 Size
 - 3.1.1 12kVA/15kVA – – H=44.53”(1080.2) W=15.75”(400) D=44.39”(1127.54)
- 3.2 Unit Weight
 - 3.2.1 12kVA – 719 lbs. (326.1kg)
 - 3.2.2 15kVA – 739 lbs. (335.2 kg)
- 3.3 Printed Circuit Board (PCB)
 - 3.3.1 All PCB's shall be Double Sided/2 Layer minimum
 - 3.3.2 All connection to the PCBA shall be locking, and polarized, except for fast-on connections, which should be kept to a minimum
 - 3.3.3 The assembly shall comply with IPC Class 2 standards
 - 3.3.4 All large components shall be glued to the board with RTV (silicon)
- 3.4 Fans
 - 3.4.1 Fans shall be designed for easy removal by field service personal from the top of the unit
 - 3.4.2 Fans used in the system should be the same fan in order to reduce spare parts of different fans
 - 3.4.3 Fans shall have fault detection circuitry

4.0 Environmental and Safety Agency

12kVA, 15kVA – POWERVAR Isolated On-Line UPS Specifications

- 4.1 Temperature
 - 4.1.1 Operating: 0°C to 40°C (32°F to 104°F)
 - 4.1.2 Transit & Storage: -20°C to 60°C (-4°F to 140°F)
 - 4.1.3 Heat sink Over Temperature:
 - 4.1.3.1 If the INVERTER heat sink temperature exceeds 85°C ($\pm 5^\circ\text{C}$), then the system shall transfer to bypass. The system will stay in bypass until the heat sink temperature drops below 70°C ($\pm 5^\circ\text{C}$), and then will transfer back to the inverter. If bypass is not available, the inverter shall shut down, until the temperature drops below 85°C, and the system is turned on again via the front panel switch.

- 4.2 Altitude
 - 4.2.1 Operating: 2,000 meters (6,500 ft.) above sea level, de-rate 3% above 2,000 meters
 - 4.2.2 Transit: 12,000 meters (40,000ft.)

- 4.3 Humidity
 - 4.3.1 5%-90% non condensing

- 4.4 Audible Noise
 - 4.4.1 60dBA@1 meter, from the front of the unit

- 4.5 EMC
 - 4.5.1 High Voltage:
 - 4.5.1.1 FCC Part 15 J Class A (5dB Margin minimum at all frequencies)
 - 4.5.1.2 EN 55022 Class A/CISPR 22 (5dB Margin minimum at all frequencies)
 - 4.5.1.3 EN 50091-2
 - 4.5.1.4 IEC 61000-3-2

- 4.6 Safety Agencies
 - 4.6.1 High Voltage:
 - 4.6.1.1 UL1778
 - 4.6.1.2 CSA22.2 No. 107.1
 - 4.6.1.3 IEC 62040, w/CB Report and Certificate
 - 4.6.1.4 CE Marking

12kVA, 15kVA – POWERVAR Isolated On-Line UPS Specifications

4.6.2 All units RoHS compliant

5.0 Input

5.1 Nominal Input

5.1.1 Voltage (Set by Front Panel Display):

5.1.1.1 High Voltage Models

5.1.1.1.1 200/208/220/230/240 VAC

5.1.2 Voltage range :

5.1.2.1 -30% to +15% of selected input voltage

5.1.2.1.1 System shall not transfer to batteries within this range

5.1.2.1.2 System shall be capable of 100% load operation in this range

5.1.2.2 < 6% Hysterisis, under all full load conditions.

5.2 Input Power factor:

5.2.1 Greater than 0.95 (IGBT design preferred)

5.3 Input Current THD:

5.3.1

	25% R-Load	50% R-Load	75% R-Load	100% R-Load
-30%	12.0%	8.0%	5.0%	5.0%
NOM	12.0%	8.0%	5.0%	5.0%
+15%	12.0%	8.0%	5.0%	5.0%

5.3.2 High voltage units must comply with IEC 61000-3-2

5.3.3 Must comply under 100% Resistive Load and while charging the batteries with full charging current

5.4 Frequency:

5.4.2 Manual 50/60Hz selectable

5.4.2.1 Output frequency

A. Narrow Window - $\pm 0.5\text{Hz}$; 0.1Hz hysteresis; lock frequency to selection outside of window

B. Wide Window - $\pm 3.0\text{Hz}$; 0.1Hz hysteresis; lock frequency to selection outside of window

5.4.2.2 Manual frequency conversion: input frequency range = 45Hz to 65Hz

5.5 Frequency Tolerance:

5.5.1 ± 5 Hz. (before switching to batteries)

5.5.2 ± 3 Hz line synchronizes.

5.6 Protection:

12kVA, 15kVA – POWERVAR Isolated On-Line UPS Specifications

- 5.6.1 Re-settable circuit breaker
- 5.7 Input connector type:
 - 5.7.1 Hardwire, terminal block for 1Ph input with L1, N, GND.
- 5.8 Input Current Limit:
 - 5.8.1 150% of nominal input current
- 5.9 Inrush current:
 - 5.9.1 Less than 6X of rated input current
- 6.0 Output – Inverter Operation**
- 6.1 Waveform:
 - 6.1.1 Pure sine wave
- 6.2 Voltage:
 - 6.2.1 High Voltage Models:
 - 6.2.1.1 200/208/220/230/240 VAC (See Section 16)
- 6.3 Inverter voltage is selected when the input is selected by the front panel display, as the input and output voltage shall match.
- 6.4 Voltage THD:
 - 6.4.1 Less than 3%THD @ full resistive load
- 6.5 Voltage Regulation:
 - 6.5.1 $\pm 3\%$ of nominal on output terminal block, under any line or load condition
- 6.6 Voltage Transient (Step Load) Response:
 - 6.6.1 $\pm 4\%$ of nominal for a 50% step load change (50% to 100% or 100% to 50%)
 - 6.6.2 $\pm 6\%$ of nominal for a 100% step load change (0% to 100% or 100% to 0%)
- 6.7 Voltage Recovery Time:
 - 6.7.1 Return to $\pm 3\%$ of nominal within 3 cycles
- 6.8 Crest Factor:
 - 6.8.1 3:1 (Peak Current / RMS Current)
- 6.9 Frequency:
 - 6.9.1 Normal Mode (AC In – AC Out) User selectable by dip switch
 - 6.9.1.1 Normal (Default)
 - 6.9.1.1.1 50/60Hz ± 3 Hz

12kVA, 15kVA – POWERVAR Isolated On-Line UPS Specifications

- 6.9.1.2 Free Running
 - 6.9.1.2.1 50/60 Hz ± 0.1 Hz
- 6.9.2 Battery Mode (DC In – AC Out)
 - 6.9.2.1 50/60Hz ± 0.1 Hz
- 6.10 Overload:
 - 6.10.1 125% for 2 min
 - 6.10.2 150% for 30 Seconds
 - 6.10.3 300% for 500ms (inverter mode), transfer to bypass
- 6.11 Efficiency:
 - 6.11.1 AC to AC -- Greater than 85% (Input terminal block to output terminal block, include output xfmr)
 - 6.11.2 DC to AC – Greater Than 87% (Battery to Output Terminal Block, includes output xfmr)
- 6.12 Under output short circuit, the system shall be transferred to bypass, if the bypass is available to clear the fault, the system shall transfer back to inverter.
- 6.13 Slew rate:
 - 6.13.1 Less than 0.5Hz per second
- 6.14 Input Back-feed protection:
 - 6.14.1 UPS shall comply with UL 1778 and IEC 62040
- 6.15 The inverter must function with the following types of loads:
 - 6.15.1 Resistive
 - 6.15.2 Inductive to 0.6 PF
 - 6.15.3 Capacitive to 0.6 PF
 - 6.15.4 Switched Mode Power Supplies without PFC
- 6.16 The inverter should be designed as a Half Bridge utilizing IGBT's. This should support all the loads listed in 6.15
- 7.0 Static Bypass Switch (Internal)**
 - 7.1 The static bypass switch shall be used to transfer the critical load from UPS supplied power to mains supplied power without interruption.
 - 7.2 The static bypass switch shall be a solid state device rated for 100% continuous duty. It shall not have any mechanical current carrying components.
 - 7.3 The static bypass shall be protected by a semi-conductor fuse. The I^2T of the fuse shall be greater than the I^2T of the SCR to ensure that the fuse will blow before the SCR will fail. The fuse will also need to be sized to handle the overloads without opening.

12kVA, 15kVA – POWERVAR Isolated On-Line UPS Specifications

7.4 The UPS will automatically transfer uninterrupted to bypass mode under the following conditions:

§ Inverter overload exceeds the UPS maximum ratings

§ Inverter failure

§ Batteries are depleted, and bypass is available

7.4.1 If the bypass line is as below, than the transfer shall be inhibited.

The BYP LED will blink to indicate that the bypass is unavailable and the output will shut down.

§ Bypass frequency is greater than ± 5 Hz

§ Bypass voltage is greater than $\pm 10\%$ of the set nominal voltage

7.5 Manual Transfer:

7.5.1 The system will transfer to bypass without interruption:

§ Bypass frequency is less than or equal to ± 5 Hz

§ Bypass voltage is within $\pm 10\%$ of the set nominal voltage

7.5.2 The system will not transfer to bypass if the above conditions are not met. The system shall stay in inverter mode until the conditions are met and the BYP button is pressed again.

7.6 Overload:

7.6.1 125% for 10 minutes

7.6.2 150% for 500ms

7.6.3 1000% for 1 cycle

8.0 Batteries & Charging

8.1 General:

8.1.1 The batteries shall be VRLA

8.1.2 The batteries shall be replaceable while the system is on, without interruption to output (Hot Swappable)

8.2 Backup time:

8.2.1 5 minutes on internal batteries

8.2.2 30 minutes additional, with each added battery cabinet

8.3 Battery Voltage:

8.3.1 The battery string nominal voltage will be 288 VDC (24 Batteries)

8.3.2 Each battery in the string will be a 12V type, with 6 cells

8.4 Battery MFG and Type:

8.4.1 12kVA Models – CSB HR1234WFR/ HR1251WFR or equivalent approved by PVI

8.4.2 15kVA Models – CSB HR1234WFR/ HR1251WFR or equivalent

12kVA, 15kVA – POWERVAR Isolated On-Line UPS Specifications

approved by PVI

- 8.4.5 Batteries must have flame retardant cases
- 8.5 Charging Current:
 - 8.5.1 2.5 ADC
- 8.6 Float Voltage and Temperature Compensation:
 - 8.6.1 The float voltage shall be 2.275V/Cell (327.6 VDC)
 - 8.6.2 The system shall monitor the temperature at the battery compartment. The thermistor shall be as close to the battery case as possible.
 - 8.6.3 If the battery temperature exceeds 35°C, then compensation to the float charge shall be adjusted by the following formula, and the float voltage shall be decreased:

§ -3.0mV/°C/Cell
- 8.7 Low Battery Shutdown:
 - 8.7.1 The unit shall shut down when the batteries reach 1.67V/Cell
 - 8.7.2 The system shall maintain a full sine wave, without flat topping, under full linear load, down to 1.67V/Cell
 - 8.7.3 The system shall have the capability of having the unit Automatically or Manually Restart upon AC being restored after a low battery shutdown. This shall be settable through the front panel
- 8.8 Over-temperature Protection:
 - 8.8.1 The battery charger shall be disabled, and charging to the battery shall stop if the battery temperature exceeds 50°C. The charger can enable itself again when the temperature drops to 45°C.
 - 8.8.2 If the temperature is exceeded, a continuous audible alarm and an alarm on the display shall be sent. The alarm can be silenced from the display.
 - 8.8.3 The charger must operate normally in a 40°C external ambient. Proper cooling must be given to the battery compartment
- 8.9 Reverse Batteries:
 - 8.9.1 The system will have reverse battery protection, which shall be recoverable by replacing a fuse. All components, other than the fuse shall remain in working condition.
- 8.10 Over-Voltage Protection:
 - 8.10.1 If the battery voltage exceeds 334.0 VDC, the charger shall be turned off, and an alarm sent.
- 8.11 External Battery Cabinets:
 - 8.11.1 The external battery cabinets will have its own charger, which will get AC power from the UPS.

12kVA, 15kVA – POWERVAR Isolated On-Line UPS Specifications

- 8.12 Batteries must be mechanically disengaged for safe transport per DOT regulation via external jumper
- 8.13 System must be supplied with a DC breaker with a method of shunt trip for computer room applications.

9.0 Low-Impedance Isolation Transformer

- 9.1 General:
 - 9.1.1 Transformer efficiency shall be greater than 95%, only if we meet section 6.11.1
 - 9.1.2 The input impedance shall be less than 4%, all winding combinations
 - 9.1.3 The transformer shall have less than 3% voltage regulation
 - 9.1.4 The transformer shall be UL recognized under OBJY2, UL Class H (180°C) or greater
 - 9.1.5 The transformer shall be constructed with copper wire only.
- 9.2 Let Through Voltage:
 - 9.2.1 Normal Mode – less than 10 Vpk**
 - 9.2.2 Common Mode – less than 0.5 Vpk**

10.0 Indicators

- 10.1 Front panel will have LCD display for the following:
 - 10.1.1 Input Frequency (Hz)
 - 10.1.2 Output Frequency (Hz)
 - 10.1.3 Input voltage (VAC)
 - 10.1.4 Output Voltage (VAC)
 - 10.1.5 % LOAD
 - 10.1.6 Alarm (Overload, Low Battery)
 - 10.1.7 Battery Status (VDC, % remaining)
 - 10.1.8 Unit Status (Normal/Inverter, Bypass, Backup)
 - 10.1.9 Fault
 - Input over voltage
 - Output over voltage
 - DC over voltage
 - Output over current
 - Overheat
 - Output under voltage
 - DC under voltage
- 10.2 Intermittent Audible alarm for:

12kVA, 15kVA – POWERVAR Isolated On-Line UPS Specifications

- 10.2.1 Input Power Failure/Battery Discharging
- 10.2.2 Frequency out of range
- 10.2.3 Overload <110%
- 10.2.4 Delete
- 10.2.5 Battery failure
- 10.2.6 General Fault

- 10.3 Continuous alarm for
 - 10.3.1 Overload >110%
 - 10.3.2 Low Battery
 - 10.3.3 UPS failure
- 10.4 Push button for Alarm silence/reset/test through Front Panel Display
- 10.5 Emergency Power Off (EPO) connector TBD located on rear panel. (EPO must turn off entire unit.)
- 10.6 EPO shall trip input and battery circuit breakers.
- 10.7 EPO should turn off inverter and battery charger.
- 11.0 User Interface (Separate Serial Communication Protocol to be developed)**
- 11.1 DB-9 female connection for serial communications/simulated dry contacts
 - Pin 1: Not used.
 - Pin 2: Output, RS232 Transmit data.
 - Pin 3: Output, RS232 Receive data, and UPS shutdown command.
 - Pin 4: Output, simulated contact closure for AC fail, normally open pin.
 - Pin 5: Common Ground
 - Pin 6: Output, Simulated contact closure for low battery warning, normally open pin.
 - Pin 7: Output, Simulated contact closure for AC fail, normally closed pin.
 - Pin 8: Output, AC fail signal (high to low signal)
 - Pin 9: NC
- 11.2 USB connector for communications to a PC.
- 12.0 Connections**
- 12.1 Terminal block for hardwire connection to distribution (Breaker panel)
- 13.0 Additional Options**
- 13.1 SNMP Ethernet adapter (Internal).

12kVA, 15kVA – POWERVAR Isolated On-Line UPS Specifications

13.2 Software for unattended shutdown, control, and data logging.

14.0 Computer Platforms Supported

14.1 Windows XX, Linux, Unix, and Solaris.

12kVA, 15kVA – POWERVAR Isolated On-Line UPS Specifications

15.0 Simplified System Electrical Schematic (200/208/220/230/240 VAC System)

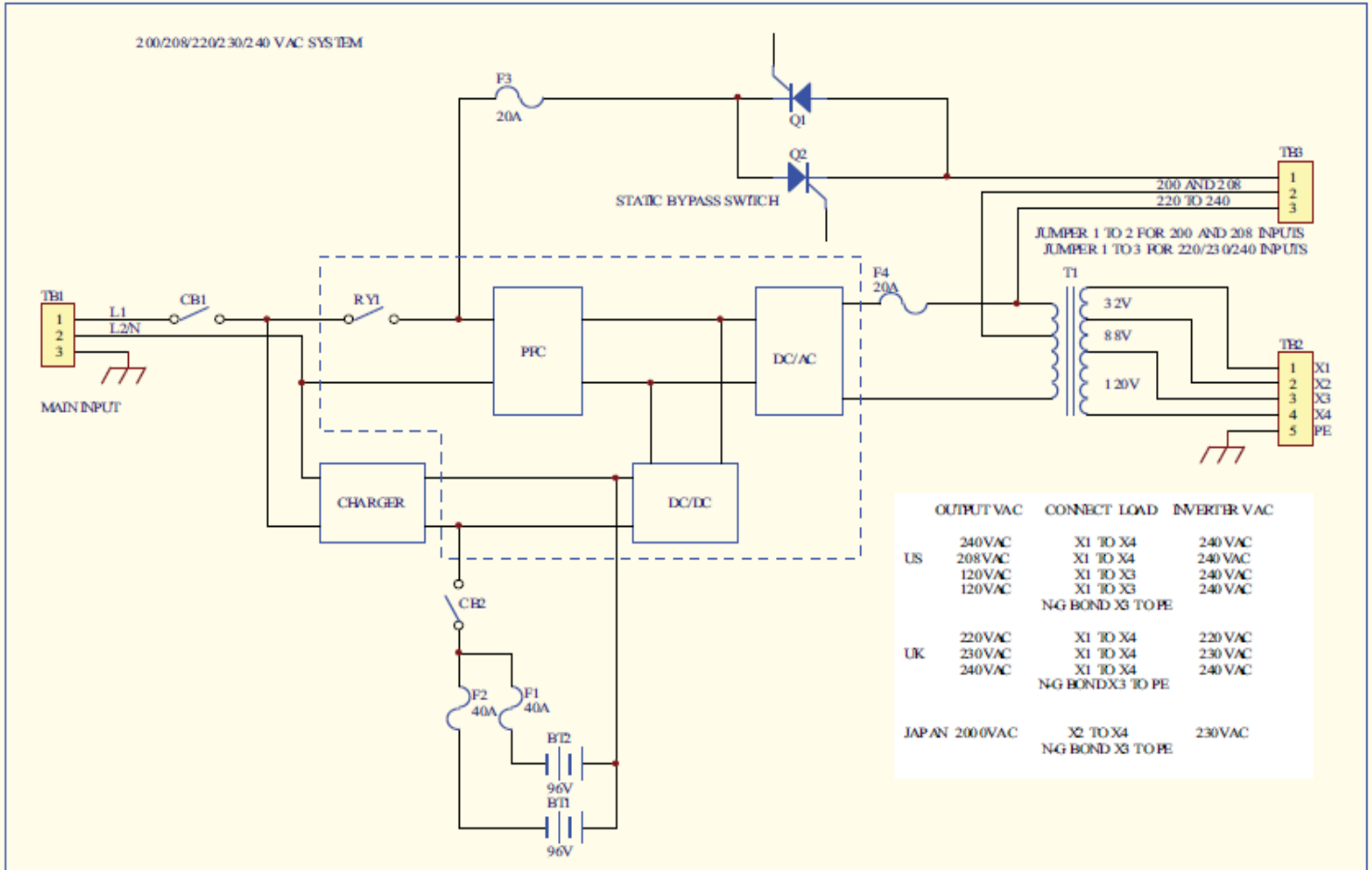

12kVA, 15kVA – POWERVAR Isolated On-Line UPS Specifications

16.0 Output Receptacle Panel Connector



HIGH VOLTAGE
TRANSFORMER

HIGH VOLTAGE
X1-X4 220/ 230/ 240
X2-X4 200/ 208
X1-X3 120
X4-X3 120

X1	X2	X4
X1	X3	X4

HIGH VOLTAGE
RECEPTACLE PANEL
PIN-OUT